



VR-LVB5

Product Instructions v2.0



Viridi E-Mobility Technology (Ningbo) Co., Ltd.

Preface

All rights reserved by Viridi E-Mobility Technology (Ningbo) Co., Ltd. (hereinafter referred to as VREMT). Without VREMT's written license or authorization, no organization or individual shall excerpt, reproduce, or disseminate any part or all of this document.

Trademark Statement

 and other trademarks of VREMT are trademarks of VREMT. All other trademarks or registered trademarks mentioned in this document are owned by their owners.

Notice

The products, services, properties, or other items you purchase shall be subject to the business contracts and provisions of VREMT. All or part of the products, services, or properties described in this document may not fall in the scope of that you have purchased or used. Unless otherwise agreed in the contract, VREMT will not make any express or implied statements or warranties for the contents of this document.

This document will be revised from time to time due to product upgrading or other reasons. Unless otherwise agreed, this document shall be used as a user guide only. All statements, information, and suggestions in this document do not constitute any express or implied warranties. Please refer to the Warranty Certificate or specific contract terms for the terms of the warranty.

Overview

This document introduces the product, installation, debugging, technical specifications, application scenarios, etc. of VR-LVB5.

Target Readers

The document is mainly for the following users:





Sales engineers

On-site installation engineers

Construction personnel

End users

Signs agreed:

	It indicates hazards with high-level risks that may cause death or serious injuries if not avoided.
	It indicates hazards with medium-level risks that may cause death or serious injuries if not avoided.
	It indicates hazards with low-level risks that may cause slight or medium injuries if not avoided.
	It's used to convey security warning information about devices or the environment, which may cause damage to devices, data loss, lower device performance or other unpredictable results if not avoided. All "Notices" involve no injury to human body.

NOTE

It refers to a supplementary explanation of key information in the text. A “Note” is not security warning information, and involves no harm to human body, devices and the environment.

Version Update History

Version	Contents Revised	Time of Revising	Reviser
V2.0	First release.	2023-9-14	Yu Zequn

Contents

Preface	2
Version Update History	3
1. Attention	6
1.1 Statement	6
1.2 Personal Safety	7
1.3 Operation Safety	7
1.4 Environment Security	8
1.5 Battery Security	10
2. Product Instructions	11
2.1 Product Description	11
2.2 Product Appearance	11
2.3 Label Description.....	12
2.4 Technical Parameters	13
2.5 Operating Mode	13
3. Transportation and Storage.....	17
3.1 Transportation Requirements.....	17
3.2 Storage Requirements	18
4. System Installation	19
4.1 Check Before Installation	20
4.2 Preparation of Tools and Instruments	22
4.3 Installation Site Selection	22
4.4 Device Installation	23
5. Electrical and Communication Connections	32
5.1 Connection to Inverter	32
5.1.1 Crimping of power cables connected to the inverter.....	32
5.1.2 Crimping of communication lines connected to the inverter	32
5.1.3 Connection between battery system and PCS	33
5.2 Connection of the battery system.....	34

5.2.1	Electrical parallel connection of the battery system.....	34
5.2.2	Parallel communication of the battery systems	36
5.2.3	Grounding.....	37
6.	Software Commissioning Guideline.....	38
6.1	Inverter List and Minimum Number of Battery Systems.....	38
6.2	Acquisition of upper computer application program	38
6.3	Connection between upper computer and battery system.....	38
6.3.1	Communication cable production.....	38
6.3.2	Connection of communication interface	39
6.3.3	Selection of communication protocol.....	40
7.	Daily Maintenance Guideline.....	42
7.1	Safety Precautions.....	42
7.2	Daily Maintenance	43
7.3	Problem Solving	44
7.4	Power Requirement for Long-Term Storage	46
7.5	Emergency Treatment.....	46
8.	Contact Information.....	48
	Shortcut	48

1. Attention

1.1 Statement

Please read this User Manual before transporting, storing, installing, operating, using and/or maintaining the devices, operate in strict accordance with the instructions, and follow signs on the devices and all safety precautions specified in the Manual. In this Manual, “devices” refer to the products, software, components, parts, and/or services; “the Company” refers to the manufacturer (producer), salesperson, and/or service provider of the device; and the term “you” refers to the entities who transport, store, install, operate, use and/or maintain the device.

Signs of “DANGER”, “WARNING”, “CAUTION”, and “NOTICE” shall not represent all safety precautions that shall be abided by. You are also required to follow relevant international, national or regional standards and industry practices. **The Company does not assume any responsibility caused by violations of safety operation requirements or violations of safety standards for design, production, and use of the device.**

The device shall be used in the environment as required in the design specifications, otherwise it may cause device failure, device dysfunction, or component damage that are not covered in the scope of the device quality warranties, or cause death, injuries to human body, or property loss that the Company does not assume the responsibility for compensation. Applicable laws, regulations, standards, norms and requirements shall be observed during transport, storage, installation, operation, maintenance, and other practices. No reverse engineering, decompilation, disassembling, adaptation, implantation, or other derived operations shall be performed on the software of the devices. No one shall study the internal logics of the devices, access the source code of the software of the devices, infringe the intellectual property rights, or disclose the test results of the software of any device by any means.

The Company shall not be liable for any of the following situations or their consequences:

- Equipment damage caused by earthquake, flood, volcanic eruption, mudslides, lightning strike, fire, war, armed conflict, typhoon, hurricane, tornado, extreme weather, force majeure;
- Operating beyond the working conditions specified in the Manual;
- Installing and using the device in an environment that does not comply with relevant international, national or regional standards;
- Installing and using the device by disqualified personnel;
- Failure to follow the operating instructions and safety warnings in the product and document;
- Disassembling and changing the product or modifying the software code without authorization;
- Damage caused by you or the third-party transportation you entrust;
- Damage caused by storage conditions not meeting the requirements in the product documentation;
- Your materials and tools do not conform to the requirements of the Instructions, local laws and regulations, and relevant standards;
- Damage caused by your and a third party’s negligence, intention, gross negligence, improper operation, or reasons not involving the Company.

”

1.2 Personal Safety



Live operation is strictly prohibited during the installation. No one shall install and disassemble cables with electricity connected, because the cable core may produce electric arc, spark, or explode, causing fire or damage to human body.



When the device is connected to the electricity, nonstandard or improper operations may cause fire, electric shock, or explode, causing death, injuries or property damage.



Watches, bracelets, rings, necklaces and other conductive items are strictly forbidden during operation to avoid burns due to electric shock.



Special insulation tools must be used to avoid electric shock injury or short circuit fault during operation. The insulation withstand voltage must meet the requirements of local laws, regulations, standards and specifications.



Special protective equipment must be used during operation, such as protective clothing, insulated shoes, goggles, safety helmets, insulated gloves, etc.

1.3 Operation Safety



Wear safety helmets and fasten their safety belts or waist ropes to sturdy structural components when working at height. Do not hang on moving unstable objects or metal with sharp edges to prevent hook slipping and falling accidents.



Tools must be fully prepared and qualified as inspected by a professional organization. Do not use tools broken or

disqualified as inspected or beyond the inspection validity period to ensure the tools are secure and not overloaded.



No drilling on the device. Drilling may lower the airtightness and electromagnetic shielding performance of the device, damage the internal components and cables, causing short circuit of the circuit board due to the metal fragments produced by drilling into the device.

General Requirements

- Do not conduct arc welding, cutting and other operations on the device without the evaluation of the Company.
- Do not install other devices on top of the device without the evaluation of the Company.
- Additional protection shall be applied on the top of the device when operating on the above of the device to avoid damage to the device.
- Please use proper tools and know how to use them properly.
- 3 or more people are required to carry the battery system.
- Wear protective gloves, safety shoes, and other protection equipment to avoid injuries when carry the device by hands.
- Use a wooden or insulated ladder for climbing operations with power on.
- Use a platform ladder with protective barrier instead of a straight ladder for climbing operations.
- Make sure that the ladder is in good condition and meets the requirements in load-bearing capacity before using it. Overload use is strictly prohibited.
- Put the ladder somewhere stable and have someone hold it during operations.
- Wear safety equipment such as goggles and protective gloves when drilling holes.
- Keep away from pre-buried pipelines or cables when drilling to avoid short circuits or other hazards.
- Cover the device when drilling to prevent debris from falling into the device, and clean the debris in time after drilling.

1.4 Environment Security



Do not place the battery system in a flammable, explosive gas or smoke environment, and any operation is prohibited in this environment.



No flammable or explosive item shall be stored in the installation area.



Do not place the device near the heat or ignition source such as smoke, fire, candle, heater or other heating equipment, or the device may be heated and cause damage or fire.



Do not install the battery system on fragile or flammable buildings or structures. Installation engineers shall evaluate the structural strength of the installing area before installing.



The battery system is in a protection level of IP55, but do not expose it to liquids such as rain or water for a long time.



Do not cover the device with other items when it's under operation to avoid damage to the device due to high temperature or fire. The device shall be installed in a ventilated and cool place without direct sunlight.



The service life and warranty period of the battery system are related to the installation environment temperature. Please use it according to technical parameters.

General Requirements

- The installation and use environment must comply with local laws and regulations as well as relevant international and regional standards for lithium battery products. Anyone using this device has an obligation to protect it from fire or other damage
- The device shall be installed in areas that are inaccessible to children, far from daily work and living areas, including but not limited to the following areas: studio, bedroom, lounge, living room, music room, kitchen, study, game room, home cinema, sunshine room, bathroom, shower room, laundry room, attic.
- Install the device away from the direction of the vehicle moving forward in the garage. It is recommended to mount the energy storage system on the wall above the bumper of the vehicle to avoid accidental collisions.
- Do not install the device in enclosed or non-ventilated areas without proper firefighting facilities or where it is difficult for firefighters to reach. Do not place flammable or explosive materials around the device.
- Install the device somewhere with cover or install an awning to avoid direct sunlight or rainwater.
- Take preventive measures when installing the device in areas with frequent natural disasters such as floods, mudslides, earthquakes, typhoons, etc.
- Do not install the device at a position that is easy to reach because its case temperature may be high when it's under operation.
- Do not install the device in moving scenarios such as ships, trains, and cars since it's not developed for environments with frequent vibration.
- The device shall be restored in clean, dry and well-ventilated environments with appropriate temperature and avoid dust and condensation.
- Do not install and operate the device beyond the scope specified in technical indicators, or its performance and security may be affected.
- Do not install or use the device or its cables outdoor (including but not limited to carrying or operate the device or its cables, plugging and connecting to outdoor signal interfaces, working at height, outdoor installation, door

opening, etc.) in adverse weather conditions such as lightning, rain, snow, and strong winds above Level 6.

- Do not install the device in environments with direct sunlight, dust, smoke, volatile gases, corrosive gases, infrared radiation, high organic solvents or salts.
- Do not install the device in environments with conductive metal or magnetic dust.
- Do not install the device in environments prone to grow microorganisms such as fungi and molds.
- Do not install the device in areas with strong vibration, strong noise sources, and strong electromagnetic field interference.
- The installation area shall comply with the requirements of local laws, regulations and relevant standards.
- Do not install the device in areas that can be submerged by water.

1.5 Battery Security

Short circuit prevention

- Wrap the exposed cable terminals on the battery when installing and maintaining the battery.
- Avoid foreign matters (such as conductive objects, screws, liquids, etc.) entering the interior of the battery to cause a short circuit.
- **Recycling and treatment**
- Please dispose of waste batteries in accordance with local laws and regulations, and do not dispose of batteries as household waste. Improper disposal of batteries may lead to environmental pollution or explosion.
- Please contact Technical Support or the battery recycling company for scrapping if the battery leaks or is damaged.
- Please contact the battery recycling company for scrapping if the battery is out of its service life.
- Do not put waste batteries in high temperature or direct sunlight.
- Avoid exposing waste batteries to high-humidity or corrosive environments.
- Do not use the faulty battery for the second time. Contact the battery recycling company for scrapping to avoid causing environment pollution.

2. Product Instructions

2.1 Product Description

VR-LVB5 is a low-voltage separated energy storage battery system applicable to on-grid and off-grid family use scenarios. It can be mounted on the wall in a cool indoor or outdoor environment without direct sunlight. It can be charged on grid or photovoltaics, and can provide electricity for family use with the premise that it's connected to a bidirectional converter, which shall be selected for type by the installation engineer based on the VR-LVB5 technical parameters and scenarios. All input and output interfaces apply to low-voltage direct current, making it safer to use and capable to connect with 8 battery systems in parallel.

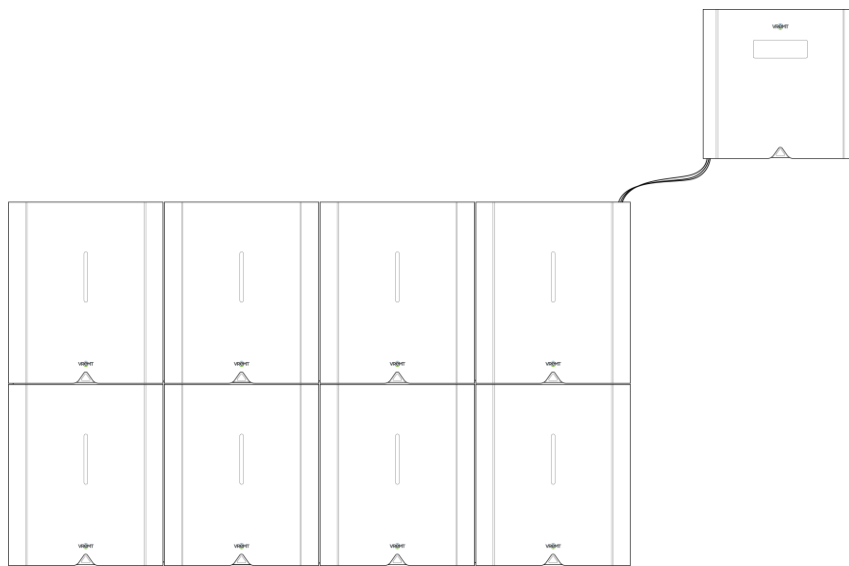

2.2 Product Appearance

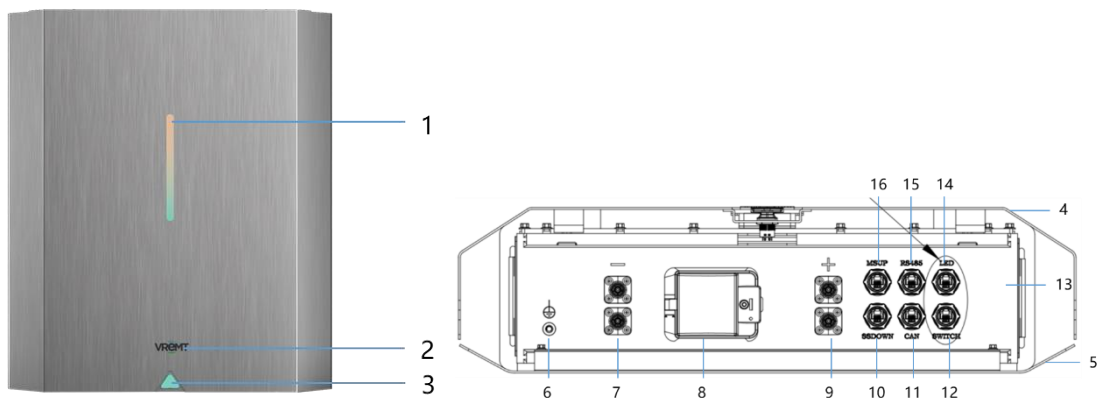

1. LED Battery Strip Light	2. LOGO	3. Switch Button
4. Battery Case	5. Brace	6. Grounding Point
7. Cathode Interface	8. Disconnecter	9. Anode Interface

10. Downlink Interface for Battery Communication (Interface to Host Computer)	11. PCS Communication CAN Interface	12. Switch Interface
13. Battery System	14. LED Battery Strip Light Interface	15. PCS Communication RS485 Interface
16. Uplink Interface for Battery Communication (Interface to Host Computer)		

2.3 Label Description

Labels on the Box

Label	Title	Meaning
	Grounding	Protecting grounding wire connecting point
—	Cathode Interface	Cathode interface for direct current, and can connect to the battery system or inverter
+	Anode Interface	Anode interface for direct current, and can connect to the battery system or inverter
SSDOWN	Downlink Interface for Battery Communication	Communication interface connecting to the battery system in parallel
MSUP	Uplink Interface for Battery Communication	Communication interface connecting to the battery system in parallel
CAN	Bidirectional Converter CAN interface	Communication interface connecting to the bidirectional converter
RS485	Bidirectional Converter RS485 interface	Communication interface connecting to the bidirectional converter
SWITCH	Switch Button	Switch button for power supply and control
LED	LED Battery Strip Light Interface	LED battery strip light interface for power supply and control

The labels are for reference only. Please subject to the actual product.

Name Plate

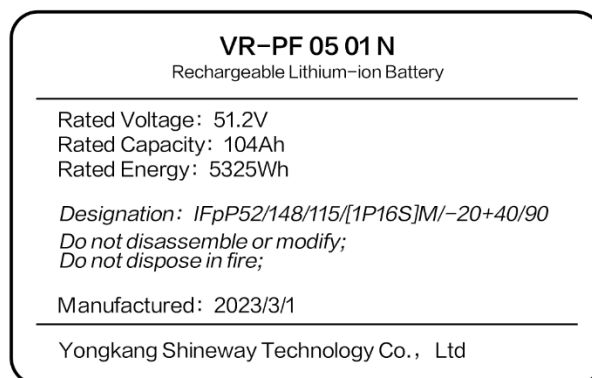

Name Plate of the Battery System

The picture is for reference only. Please subject to the actual product.

Die Zeichen dienen nur als Referenz, und die tatsächliche Gegenstände sind maßgebend.

2.4 Technical Parameters

Battery System Capacity (kWh)	5.3kWh
Cell Capacity	104 Ah
Nominal Voltage	51.2V
Operating Voltage	46.4-58.4V
Nominal Current	52A
Max Output Current	104A
Dimensions (H/W/D)	735*630*169mm
Weight (kg)	59.5 Kg
Operating Temperature	Input: 0 °C to +55°C Output: -20 °C to +55°C
Enclosure Protection Rating	IP55
Installation	Wall-mounted
Maximum Number of Parallel Machines	8 Units to 42.6kWh
Communication	RS485/CAN
Warranty	10 years
Certification	UN38.3, CE, IEC / EN62619, IEC / EN61000, ROHS, REACH, WEEE, MSDS

2.5 Operating Mode

VR-LVB5 battery system has four operating modes: Charging, Discharging, Standby, and Fault. The electricity percentage is shown with the ratio on the Green LED.

Charging (Example: 20%-90%)

When the battery is in charging, the green LED will be lightened from bottom to top, and turn to green wholly

when it's fully charged;

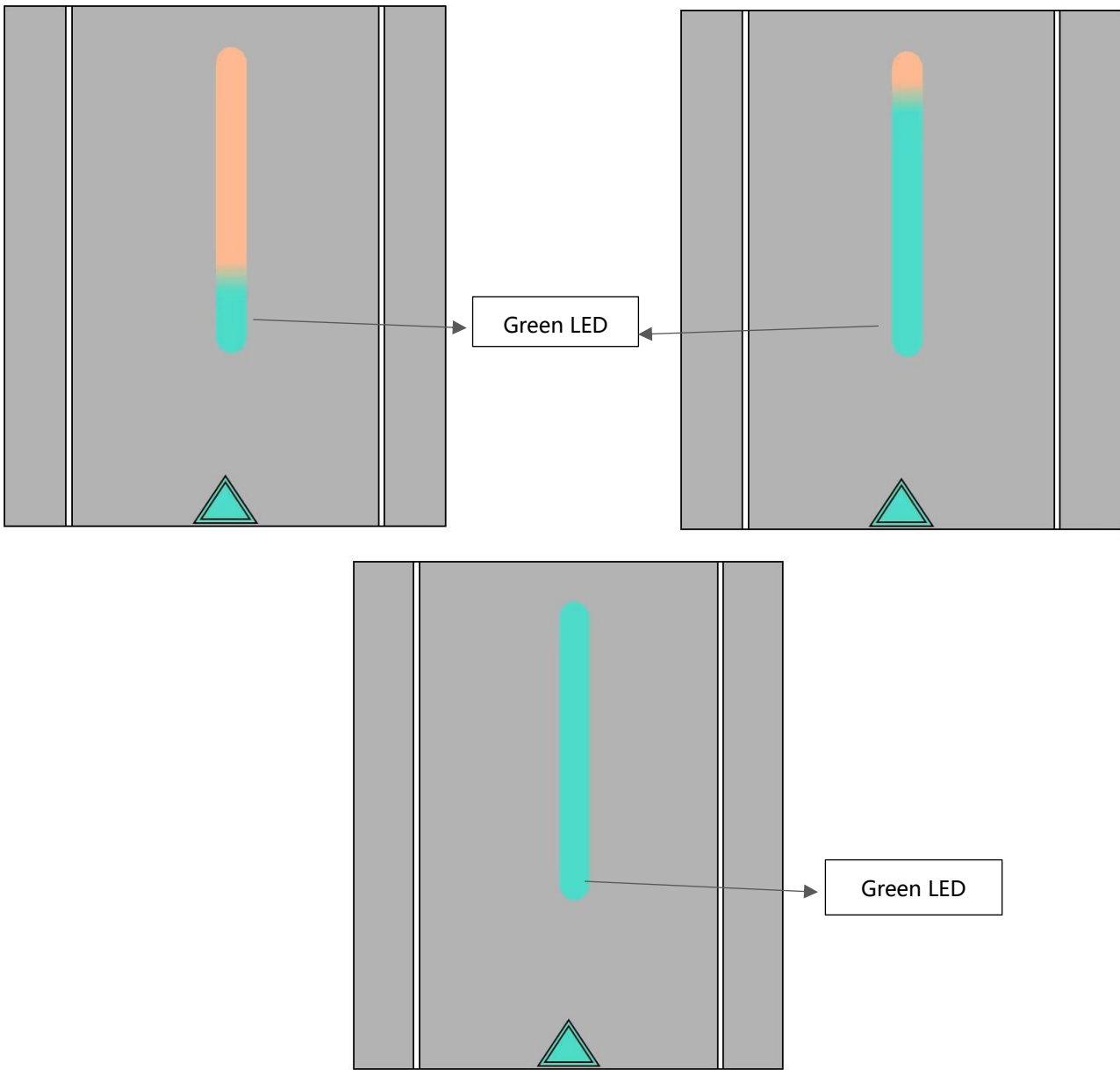

SOC: 100%

Discharging

When the battery is discharging, the yellow LED will be lightened from top to bottom, and when 10% of the stored electricity is left, the whole LED will flash.

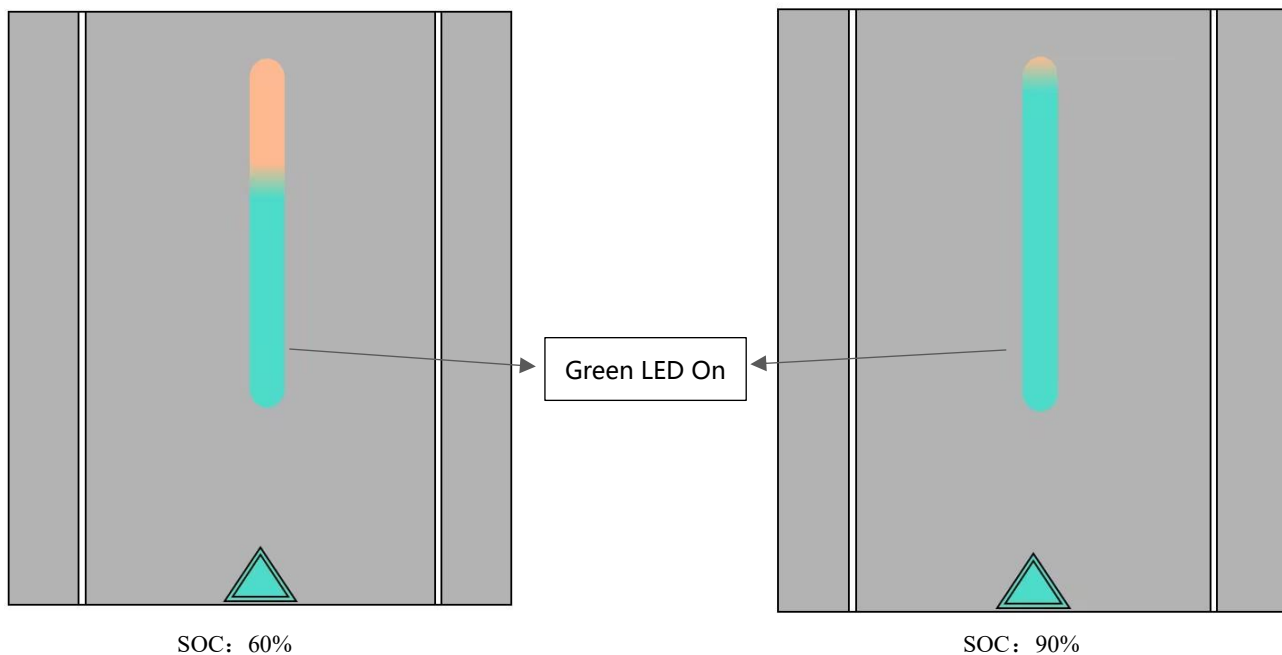

Standby



- When there is no button pressed in 60 seconds, the strip light will be off to extend the service life of the battery, and it will be lightened by pressing a button shortly;

No animation demonstration for the strip light on standby

Power On

Power on the battery by pressing the SWITCH button for 3 seconds;



- When the battery systems are connected in parallel, press and hold the SWITCH button of any battery systems can power on all battery systems;

Power Off

Power off the battery by pressing the SWITCH button for 3 seconds;



- When the battery systems are connected in parallel, press and hold the SWITCH button of any battery systems can power off all battery systems;

Normal

The SWITCH button is green.

Fault

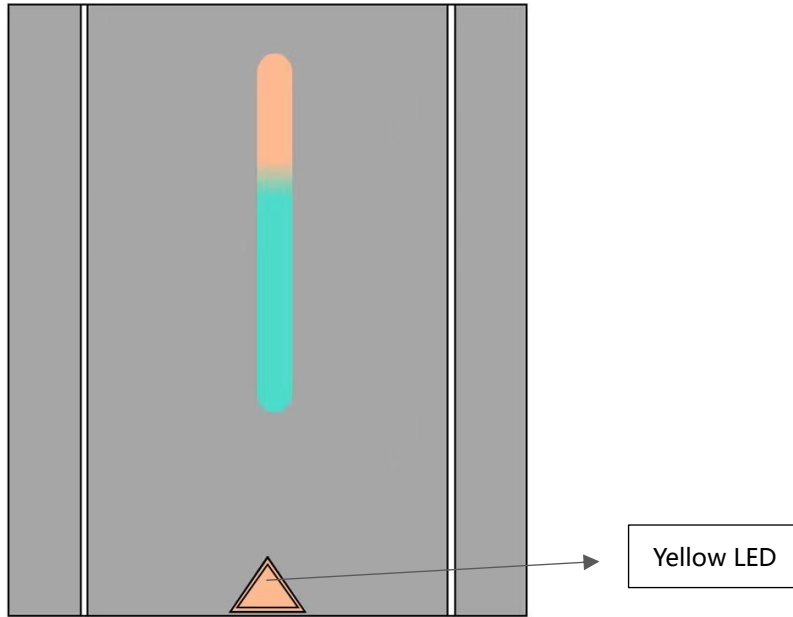

The strip light and the SWITCH button is yellow.

3. Transportation and Storage

3.1 Transportation Requirements



Don't load or unload the battery roughly to avoid the short circuit, damage (leakage, rupture, etc.), ignition or explosion of the battery.



Don't power on the battery system or connect the cable when carrying to avoid damage to the battery and interface. Carry the battery system in the direction required on the package. Any inversion, tilt, falling, mechanical impact, exposure to rain or snow, or falling into water or fire are prohibited.



During the storage and transportation of the unpacked battery, the carton shall be intact and properly placed according to the labels on the box. Do not place them upside down, sideways, upright, or aslant. Any stacking shall meet the requirements on the outer packing to avoid battery damage or scrap caused by any strike or drop.



After the package is removed, do not take the breaker, interface and other vulnerable parts as the force bearing point to avoid battery damage when carrying the battery. The housing and back plate shall be dismantled for separated handling.

General Requirements

- The battery has received the UN38.3 certification and been identified as an item in Class 9 dangerous goods.
- The battery can be directly shipped to the site and meets the requirements for vehicle, boat and other transportation modes.
- The international regulations for the transport of dangerous goods shall be followed and the regulatory requirements of the country of origin, the transit country and the destination country shall be satisfied.
- The preferred transport methods are maritime transportation or good-conditioned highway. Rail and air transports are not feasible. During the transportation, reasonable efforts shall be made to minimize the bumps and tilting.
- Maritime transportation shall follow the requirements specified in the *International Maritime Dangerous Goods Code* (IMDG Code).
- Before the transport, check the battery package to identify if it is intact. In case of any damage or odor, leakage, smoke, fire or other circumstances, the transport is prohibited.
- The carton shall be secure and solid and handled with care during the loading, unloading and transportation. Damp-proof measures shall also be taken accordingly.

- The battery shall be carried gently and no bumping is allowed. Personal safety shall also be guaranteed.
- Unless otherwise specified, dangerous goods shall not be placed in the same vehicle or container with the goods containing food, medicine, animal feed or its additives.
- When carrying faulty batteries from the site, don't take them to fuel storage areas, residential areas or other places where people can gather easily (such as public transport or elevators).
- Before carrying the faulty batteries (carbonized, leaking, swollen, water in-taking, etc.), the positive and negative terminals of the battery shall be insulated. The packed batteries shall be put into the insulated explosion-proof box and records shall be made on the outer box to indicate the site name, address, time, phenomenon, and other information.

3.2 Storage Requirements



- The battery shall be stored indoors to avoid direct sunlight or rain and kept away from source of heat and ignition. The storage environment shall be dry, clean and well ventilated without large amount of radiation (such as infrared radiation), or organic solvent, corrosive gases, or conductive metal dust.
 - In case of any failure (carbonized, leaking, swollen, water in-taking, etc.), the battery shall be transferred to the dangerous goods warehouse for separate storage, not less than 3m away from surrounding combustible materials, and scrapped in a timely manner.
 - The stored battery shall be placed as per the identification of the packaging box. Do not place it upside down, sideways, or aslant. Any stacking shall meet such requirements on the outer packing.
 - The battery shall be stored separately to avoid mixing with other devices or stacking too high. In case of a large number of stored batteries, it is recommended to have the qualified firefighting facilities, such as fire sand and fire extinguisher.
-



It is suggested that the battery system should be used in a timely manner. In terms of the battery stored for a long time, periodical re-charging is necessary to avoid irreversible damage to the battery.



If the storage period exceeds the required duration, the battery shall not be put into use unless it is checked and tested by professionals.



When the batteries are shipped, the one stored first shall be shipped first.

General Requirements

- Storage environment:

Ambient temperature: -20°C-45°C; recommended storage temperature: 25±°C.

Relative humidity: $\leq 95\%RH$; recommended relative humidity: $\leq 80\%RH$.

- During the storage, related documents that prove the compliance with product storage requirements shall be maintained, such as temperature and humidity log, photos of the storage environment, and check reports.
- The shipped batteries shall be in the same batch.

4. System Installation



Pay special attention to the positive and negative poles of the battery during the installation. The positive and negative poles of a single battery or battery string shall not be connected, or it will cause a short circuit of the battery.

Before drilling holes on the wall, please make sure to keep them away from the pre-embedded water and electricity lines to avoid any danger.



- Tighten the fastening bolts as per the torque specified herein. Check them regularly to see if they are tightened and whether there is rust, corrosion or other foreign matters, and clean them up if necessary.
 - Do not place installation tools, metal parts or other objects on the battery during the installation. When the installation is completed, clean the objects on and around the battery in a timely manner.
-



After the package is removed, do not take the breaker, interface and other vulnerable parts as the force bearing point during the handling to avoid battery damage. The housing and back plate shall be dismantled for separated handling.



- Do not use the damaged batteries (falling, crashed or swollen batteries, or batteries with pits, etc.) which may cause liquid leakage or emission of combustible gas. In case of liquid leakage, structural deformation or any form of damage to the batteries, please contact the installer or professional operation and maintenance personnel to remove and replace them without delay. Keep the damaged batteries away from other devices or combustible materials, and non-professionals shall stay away from the damaged batteries.
 - Before the installation of battery system, check it for its normal operation. In case of any of the following circumstances, the battery system shall be identified as abnormal:
 - Obvious deformation or damage of the housing of the battery system.
 - The voltage from the general positive pole to general negative pole of the battery system is much lower than the specification.
-

4.1 Check Before Installation

Check the outer packing







The packing materials and parts might be damaged during the transportation. Please check the outer packing materials of the battery before the installation for any damage (such as holes and cracks). If any damage is identified, keep the battery unpacked and contact the dealer as soon as possible. It is suggested that the packing materials should be removed within 24 hours before the installation.





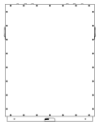

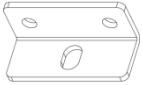

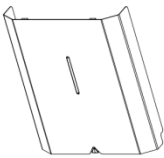



Check the deliverable



After the outer packing is removed, check the deliverable for completeness and any obvious external damage. If any part is missing or damaged, please contact your dealer.

The quantity of deliverables shipped with the carton shall be subject to the *Packing List* in the carton.

SN	Picture	Quantity	Description
1		1PCS	Battery system
2		1PCS	Back plate
3		2PCS	Hanging bracket
4		1PCS	Upper cover
5		1PCS	Bottom cover
6		1PCS	Front cover of the housing

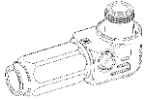
7		2PCS	Parallel cables (one black cable and one red cable)
8		1PCS	Parallel communication line
9		1PCS	LED
10		1PCS	Switch
11		2PCS	M8 nut
12		4PCS	M3x8
13		8PCS	M3x10
14		2PCS	M4x10
15		4PCS	M5x16
16		4PCS	M6x16
17		4PCS	M8*60 expansion bolt
18		1PCS	Operation Manual
19		2PCS	Inverter terminal

Note: If the parts cannot be used for installation due to undesired length or quantity, please prepare M8 stainless steel expansion bolts by yourself.

4.2 Preparation of Tools and Instruments



- The installation and protective tools listed in the table shall be prepared by the installation engineer.

Tools			
Installation	Utility knife 	Tape measure 	Torque wrench (torque range 1-12 Nm)
	Rubber hammer 	Cross-head screwdriver 	Hammer drill (10 mm)
	Spirit level 	Marker 	RJ45 crimping plier
	Hydraulic crimping tool 	Line sequence tester 	USB to RS232 tool
Protection	Insulating gloves 	Goggles 	Dust mask
	Safety shoes 	Protective gloves 	

4.3 Installation Site Selection

Requirements for installation angles



The energy storage system can only be mounted on the wall as per the following requirements

- Do not tilt the energy storage system forward or install it horizontally, upside down, backward, or sideways.

Requirements for installation site



The installation site shall be the solid brick-concrete structure, concrete wall and ground. If other types of walls or ground are selected, such wall and ground shall be made of flame-retardant materials and can support the system. See "2.4 Technical Parameters" for the weight of the energy storage system.



The storage system can be installed indoors or outdoors. In the latter case, make sure it will not be exposed to direct sunlight.

Requirements for installation space



- The installation site of the energy storage system shall not be surrounded by other devices (except the awning) and inflammable and explosive objects. Enough space (see the following figure) shall be reserved for heat dissipation and safety isolation.
- If the system is mounted on the wall, no objects shall be placed under it.

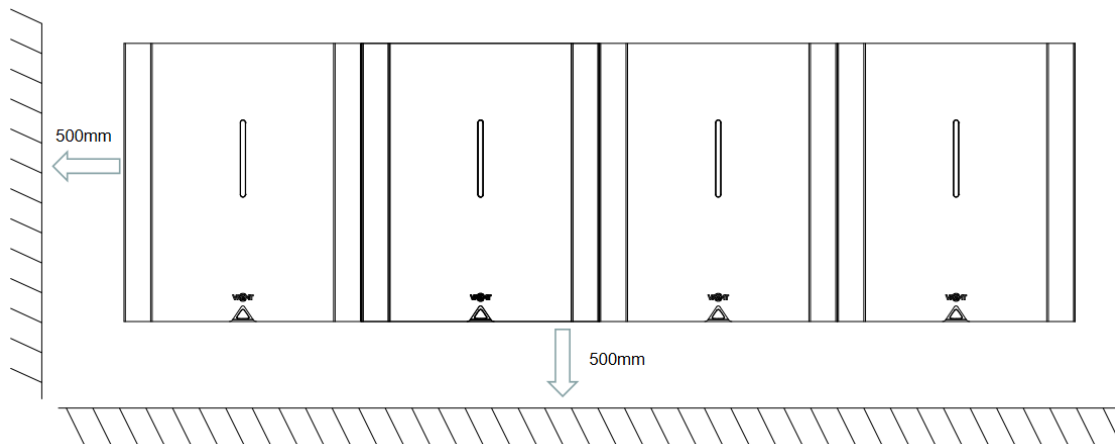

Wall-Mounted Scheme

4.4 Device Installation

Installation Instructions



The energy storage system can be installed side by side or vertically. As different installation modes may require different cable lengths, it is suggested to evaluate the scheme before installation;

The length of the standard cable in the packing list is 1m, which is only suitable for side-by-side installation;

During the installation, all parallel cables can be hidden beneath the housing.



In case of crimped parallel cables, make sure all energy storage systems share the same length.

See the following figure for the dimension of the holes for the wall-mounted battery system.

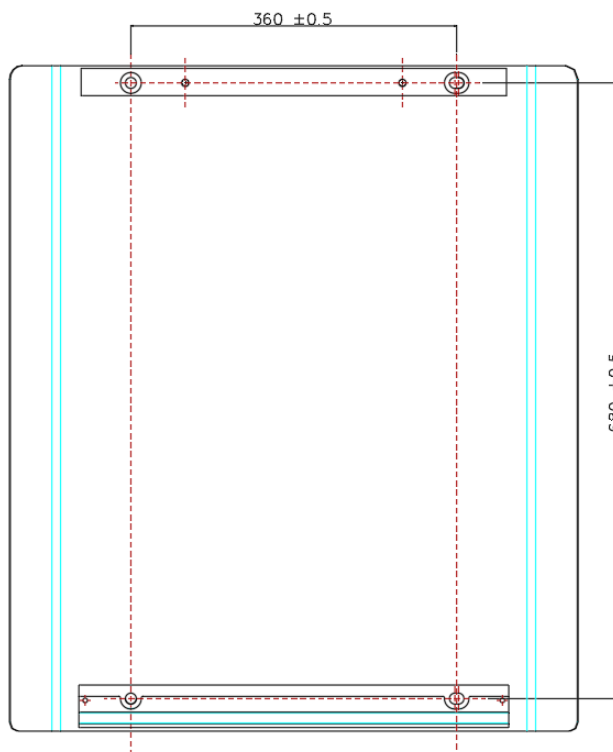

Step 1

Take the back plate as the marking template, adjust it to the level with a spirit level and make the hole sites on the wall with a marker.

Step 2

Drill holes on the marked sites with a 10 mm drill and the depth of holes shall be 60-70 mm. Stick the back plate to the wall, aligning the holes, and hammer the expansion screws into the holes with a rubber hammer. Then turn the bolts clockwise with a torque wrench and the torque shall be 3.25-9.75 Nm (for 75# brick wall)/7.8-19.5 Nm (for 150# concrete wall).

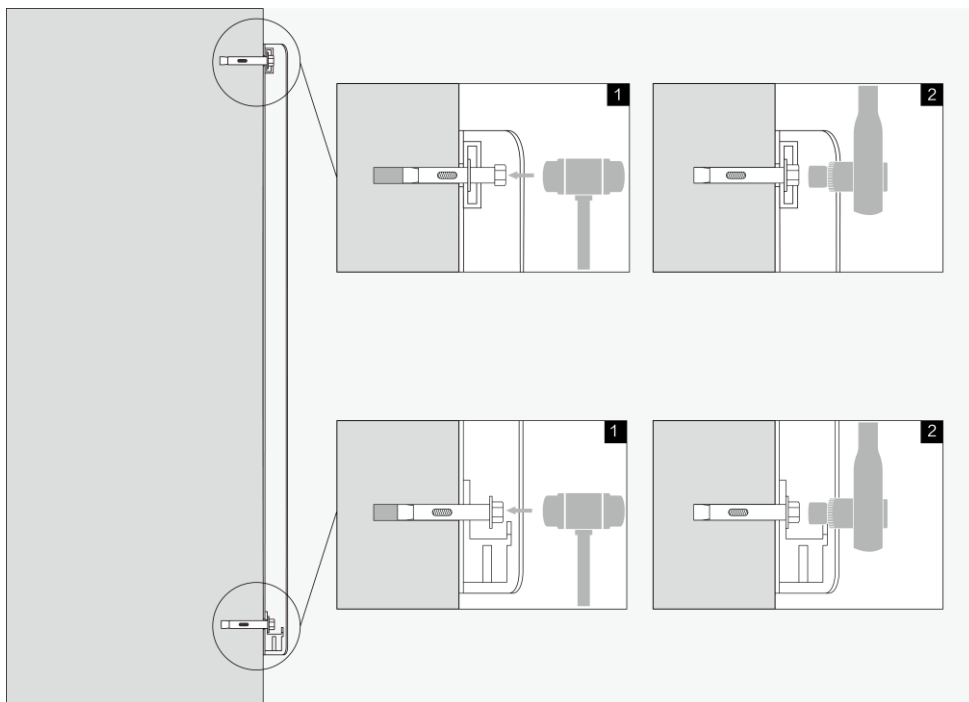

Step 3

Install the two hanging brackets to the two bolts on the top of the back plate with two M8 nuts wrenched clockwise. Do not lock them for subsequent adjustment. See the following figure for specific steps.

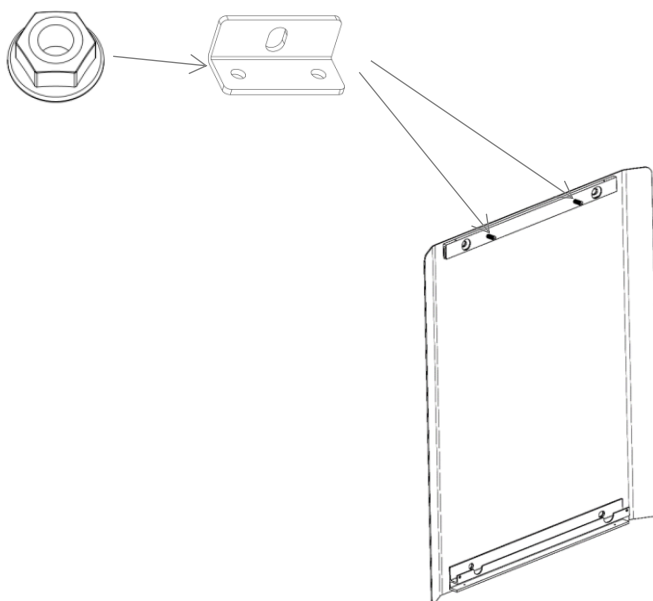

Step 4

Insert the set sill of the battery system into the backplate holder. The set sill without an aperture shall be near to the wall.

Lock the battery system and the hanging brackets with four M6x16 bolts, and the torque of the torque wrench is 6.5-10 Nm; secure the battery system with two M4x10 screws below and the torque is 2-5 Nm.

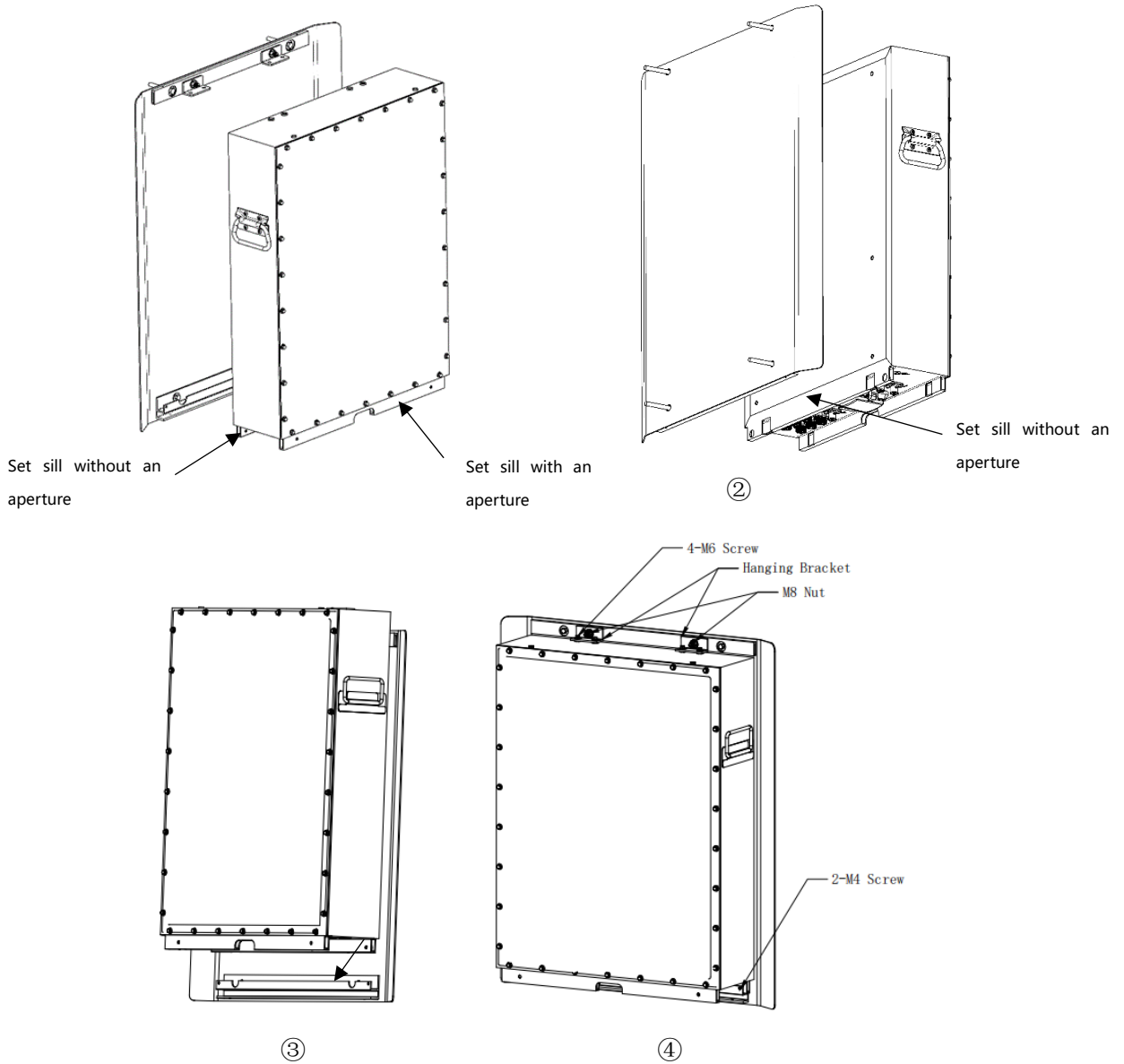

Step 5

Grounding: Connect the PE bottom line interface (as shown in the figure) to the home ground wire.



The ground wire length and type shall be determined by the customers according to their needs. The screw thread connecting bolts shall be M6 and the bolts shall be fully-threaded with a length of 10-14 mm. No requirements are proposed for the type of bolt head.

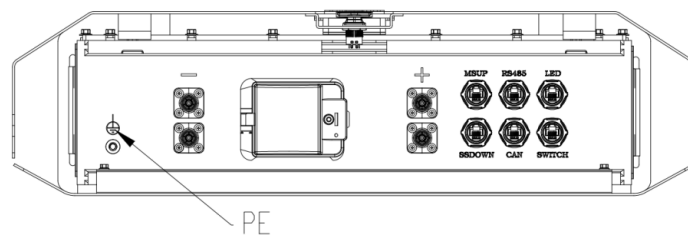

Step 6

LED installation.

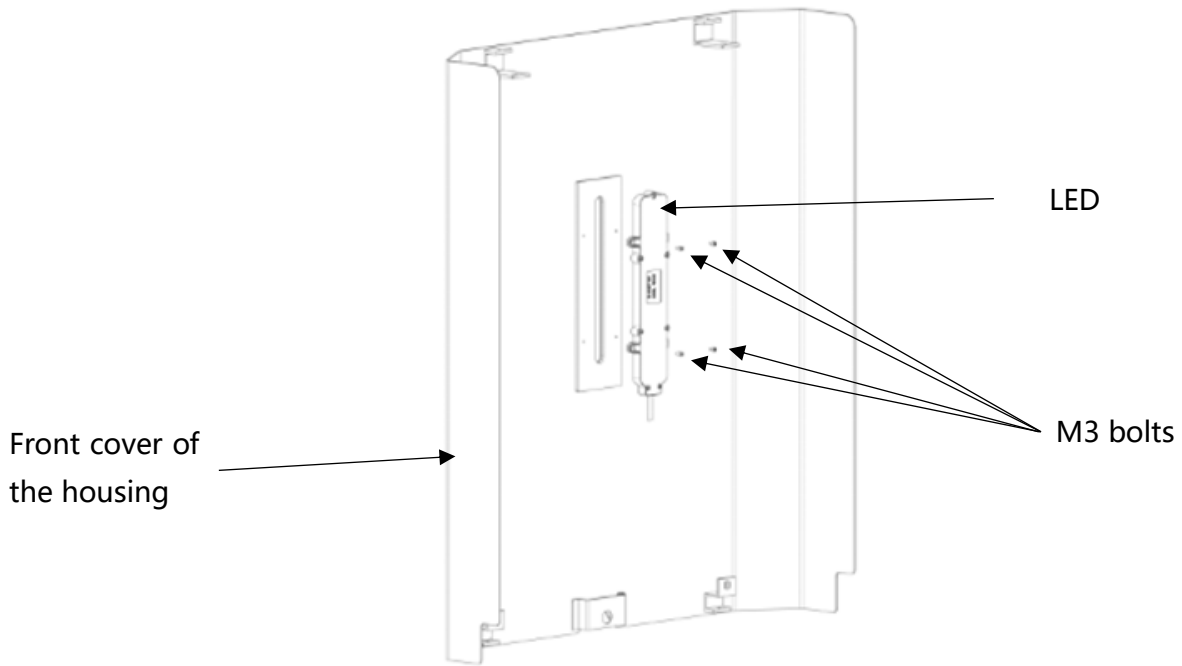

Switch installation.

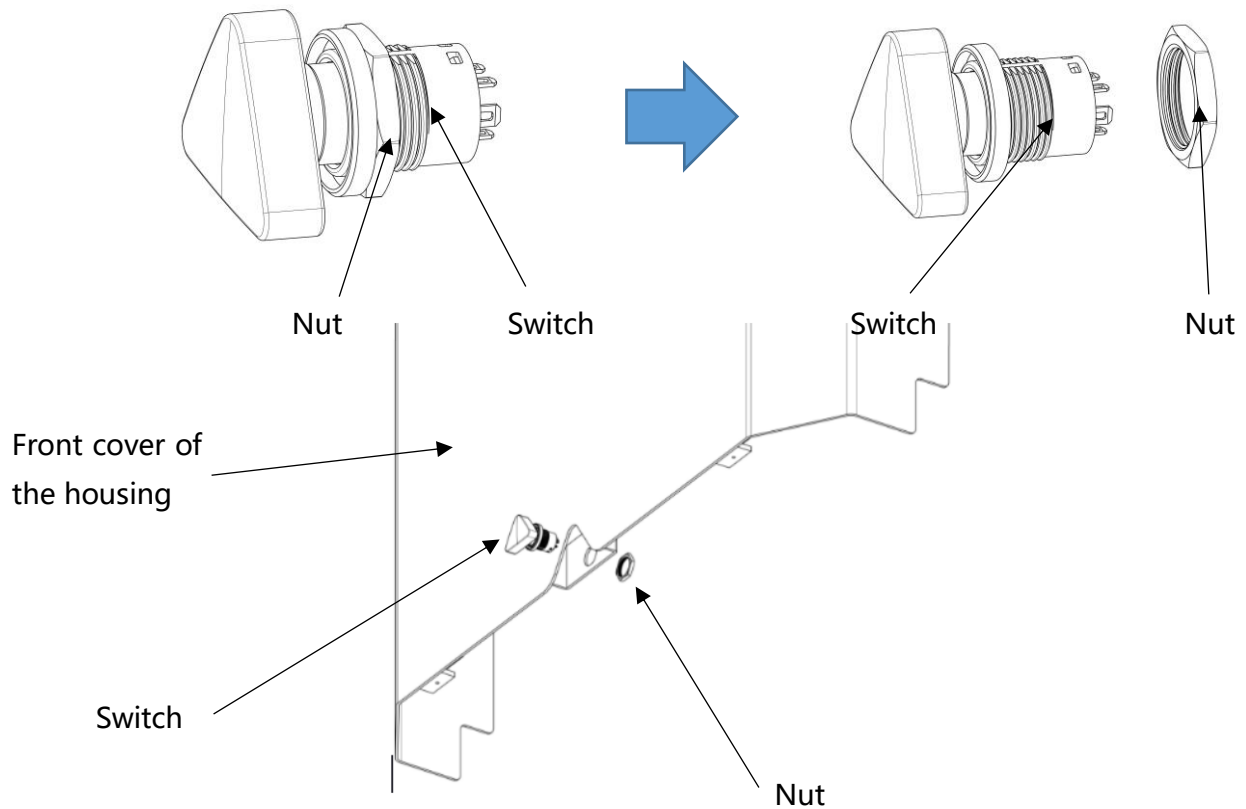

Step 7

Connect the LED strip light to the switch cable: insert the LED strip light into the port marked "LED"; insert the switch cable into the port marked "SWITCH".

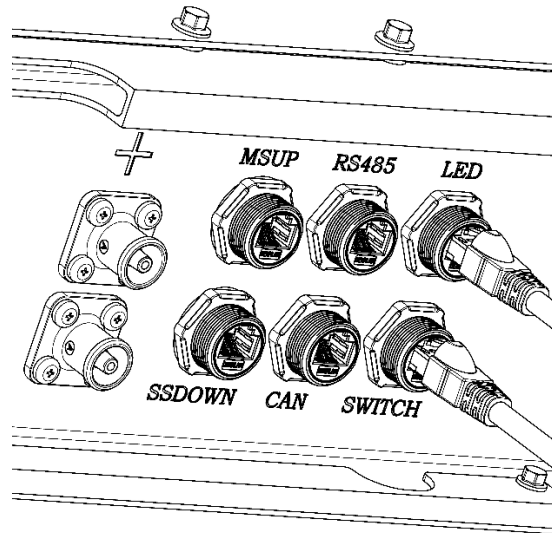

Step 8 (Single Battery System)



WARNING

Before the operation, make sure that the air switch of the energy storage system is "OFF". Wear the insulating gloves, and confirm that the PCS power supply is cut off.



CAUTION

The cables connected to the inverter shall be crimped by the installation engineer according to real conditions; Two quick-plug terminals are provided in the packing list. Please choose the AWG2# cable.

(Single battery system) Cables connection: connect the red power cable to the "+" on the PCS (connection method can be selected according to the PCS Manual) and insert the quick-plug interface into the "+" indicated in the figure (choose one from the two); connect the black power cable to the "-" on the PCS (connection method can be selected according to the PCS Manual) and insert the quick-plug interface into the "-" indicated in the figure (choose one from the two).

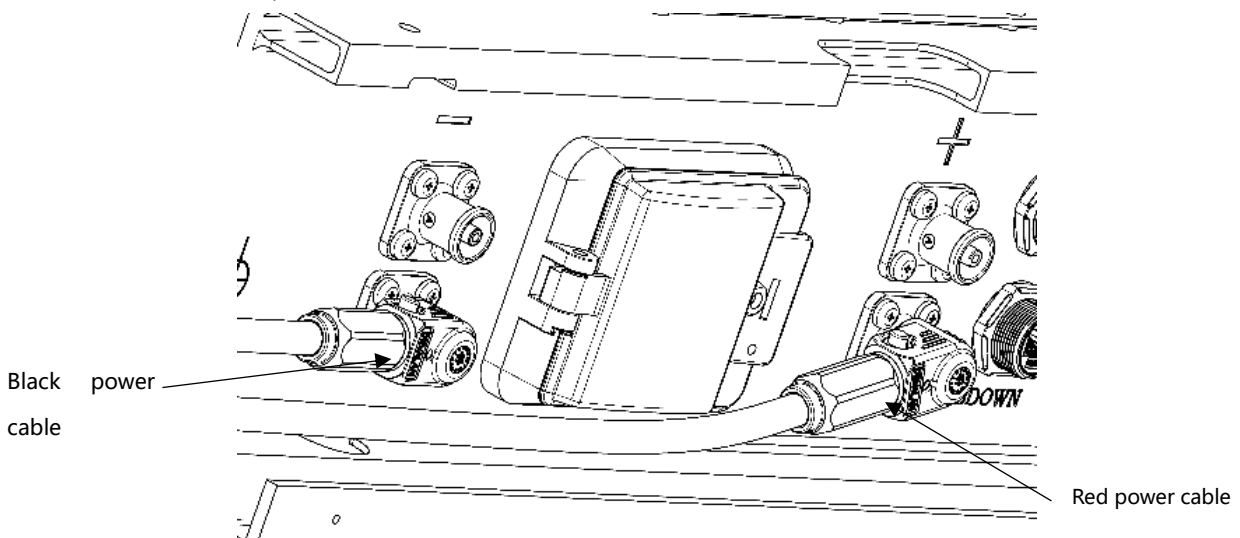

(Parallel connection of several battery systems) Power cables connection (parallel connection for ≤ 8 units):

connect the red power cable to the "+" on the PCS (connection method can be selected according to the PCS Manual) and insert the quick-plug interface into the "+" indicated in the figure; connect the black power cable to the "-" on the PCS (connection method can be selected according to the PCS Manual) and insert the quick-plug interface into the "-" (as shown in the following figure).

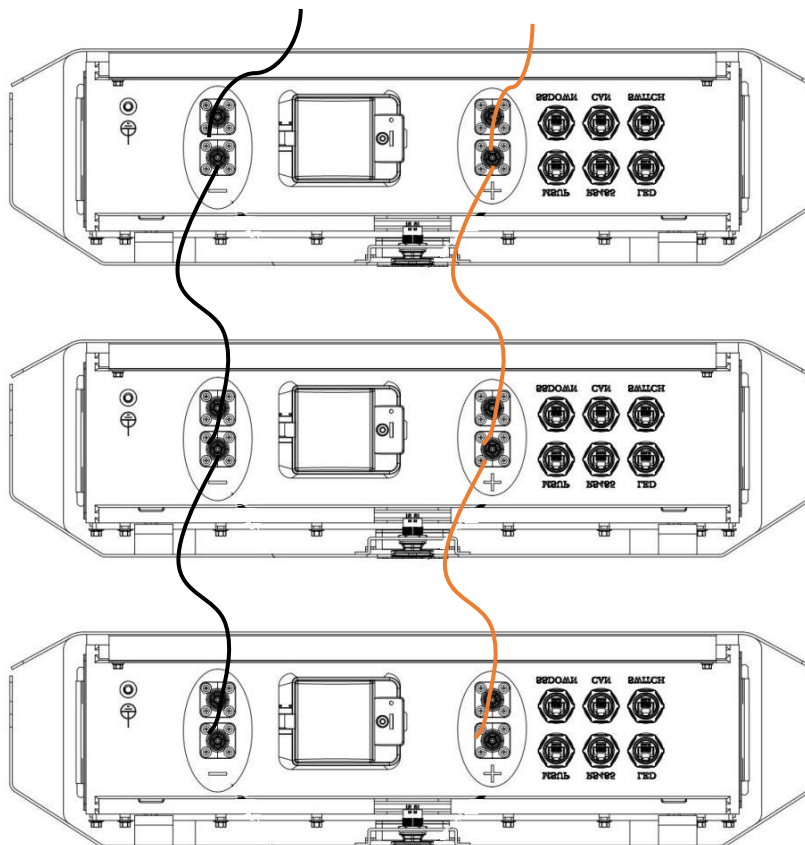

Step 9



The communication lines connected to the inverter shall be crimped by the installation engineer according to real conditions;

The communication terminal of the energy storage system is RJ45, which is self-provided.

Connect PCS communication lines. The communication lines connected to PCS shall be installed according to the communication terminal and PCS Manual. Either RS485 or CAN can be selected according to the inverter.

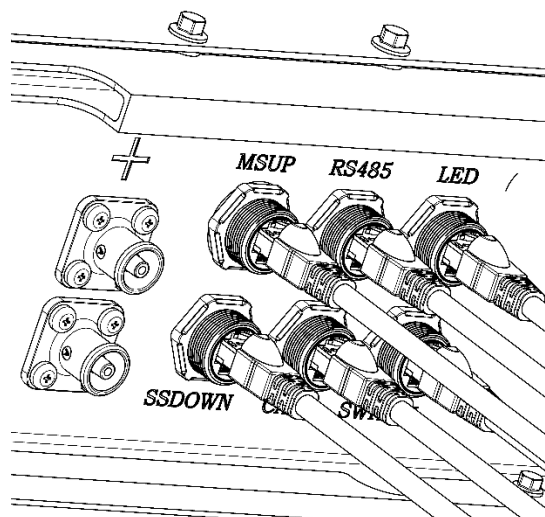

Step 10 (Connect the cables first and then install the housing)

Hang the housing to the battery system and secure it using the M5 screw with a torque of 5-8.5 Nm.

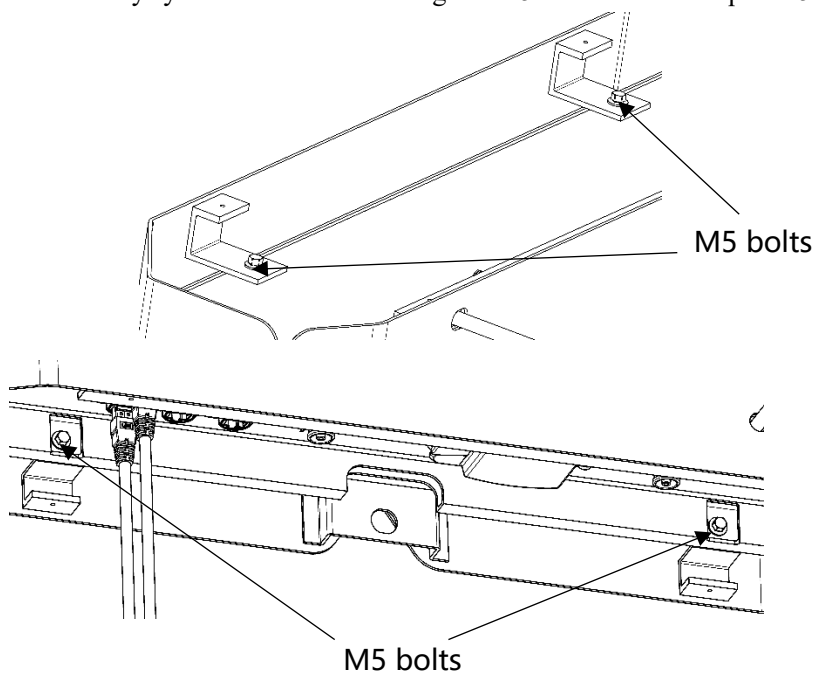

Step 11 (Connect the cables first and then install the housing)

Take out the top guard board (the one with closer hole pitch) and secure the board using 4 M4 screws with a torque of 0.6-1Nm.

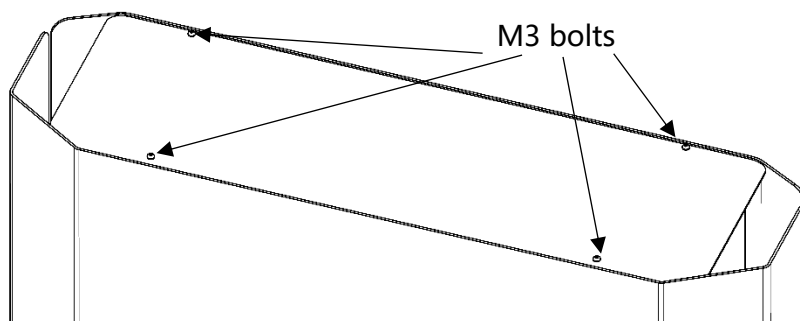

Step 12 (Connect the cables first and then install the housing)

Take out the bottom guard board (the one with wider hole pitch) and secure the board using 4 M4 screws with a torque of 0.6-1Nm.

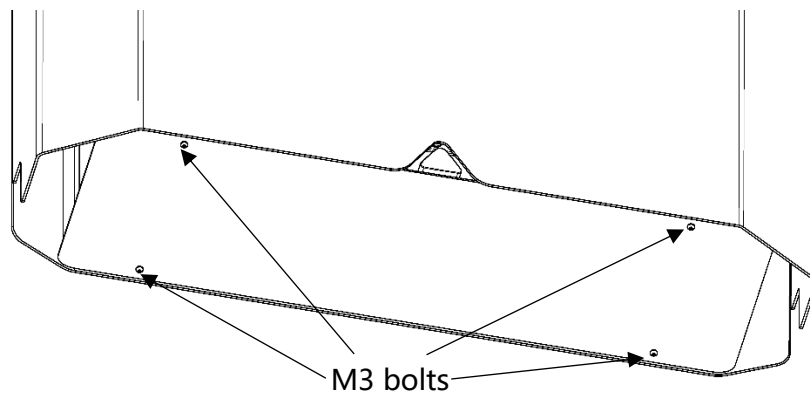

5. Electrical and Communication Connections

5.1 Connection to Inverter



- Before the operation, make sure that the air switch of the energy storage system is "OFF". Wear the insulating gloves, and confirm that the PCS power supply is cut off;
 - Please choose the officially adapted inverter. See "Inverter List and Minimum Number of Energy Storage Systems" for reference;
 - Power on the inverter first before the energy storage system, make sure that the air switch of the energy storage system is "ON" and push the switch button.
 - Power off the inverter first before the energy storage system, make sure that the air switch of the energy storage system is "OFF" and push the switch button.
-



- The cables connected to the inverter shall be crimped by the installation engineer according to real conditions;
 - Two quick-plug terminals are provided in the packing list. Please choose the AWG2# cable.
-

5.1.1 Crimping of power cables connected to the inverter

Each battery system has two pairs of power cable terminals  , one pair of P+ and one pair of P-. Please

crimp the lines with the professional hydraulic tool  .

5.1.2 Crimping of communication lines connected to the inverter



- Please choose the officially adapted inverter. See "6.1 Inverter List and Minimum Number of Battery Systems" for reference
 - During the installation process, please check if the corresponding wire sequence is correct. Only after
-

confirming that there are no errors can the inverter or battery system be turned on



- Length of the communication line: on the premise of facilitating the assembly, the length shall be ≤ 5 meters. The recommended line is the CAT6A 8-core twisted-pair shielded signal cooper cables;
- The definition of this interface is limited to the communication interface connected to the battery system. Please refer to the inverter's manual for the definition of the communication interface on the inverter side.

Definition of the interface

The interface connected to the inverter shall follow CAN/RS485 protocol. See the following table for the definition of the interface.

CAN 8P8C vertical RJ45 socket		RS485 8P8C vertical RJ45 socket	
Pin NO.	Definition	Pin NO.	Definition
1	RS232_TXD	1	RS232_TXD
2	RS232_RXD	2	RS232_RXD
3	COM_GND	3	COM_GND
4	CANH1	4	CANH1
5	CANL1	5	CANL1
6	NC	6	NC
7	485B_2	7	485B_2
8	485A_2	8	485A_2

The recommended standard tools for communication line crimping are as follows:

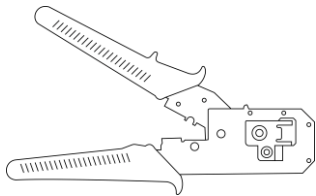

RJ45 crystal head crimping tool

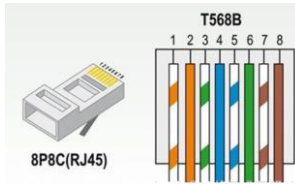

Interface pin number

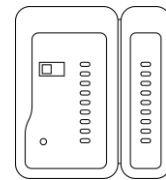

Line sequence tester

5.1.3 Connection between battery system and PCS

Connect the P+ and P- terminals beneath the energy storage system to the P+ and P- terminals of the PCS with the quick-plug power cables. Then connect the CAN interface or RS485 interface of the battery system to the CAN interface or RS485 interface of the PCS with the communication lines, as shown in the following figure.

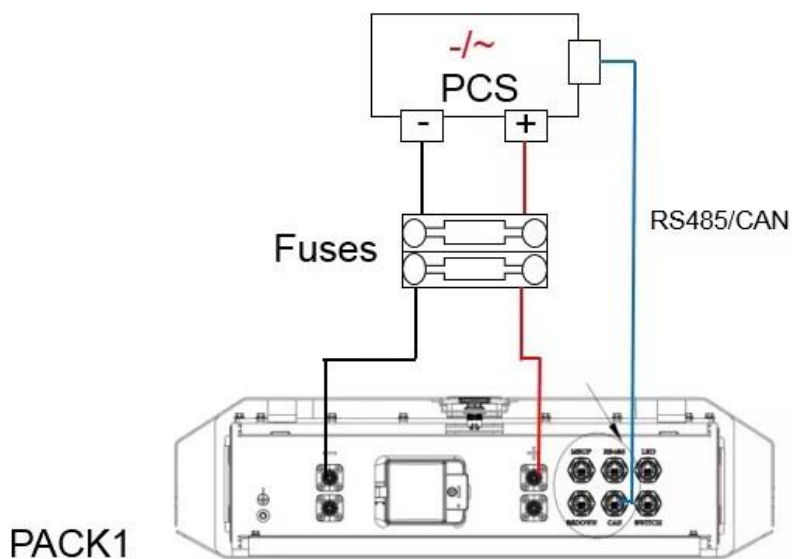

Single Battery System Connection

5.2 Connection of the battery system

5.2.1 Electrical parallel connection of the battery system

The battery system can be connected in parallel to increase the capacity and power. If several battery systems are connected in parallel, one battery system (PACK 1) will operate as the main battery system and others will serve as the secondary battery systems (PACK 2-8). Connect P+ and P- terminals of the main battery system to the PCS and other P+ and P- terminals to the secondary battery systems for capacity expansion.

For other secondary battery systems, each P terminal shall be connected to the terminals of other secondary battery systems.

The first wiring method



- Fuses shall be connected to the P+ and P- terminals of PACK1, please prepare yourself.
- Due to the limited discharge capacity of the connecting cable and interface, the power of the parallel energy storage systems connected with this method is up to 5 kW;

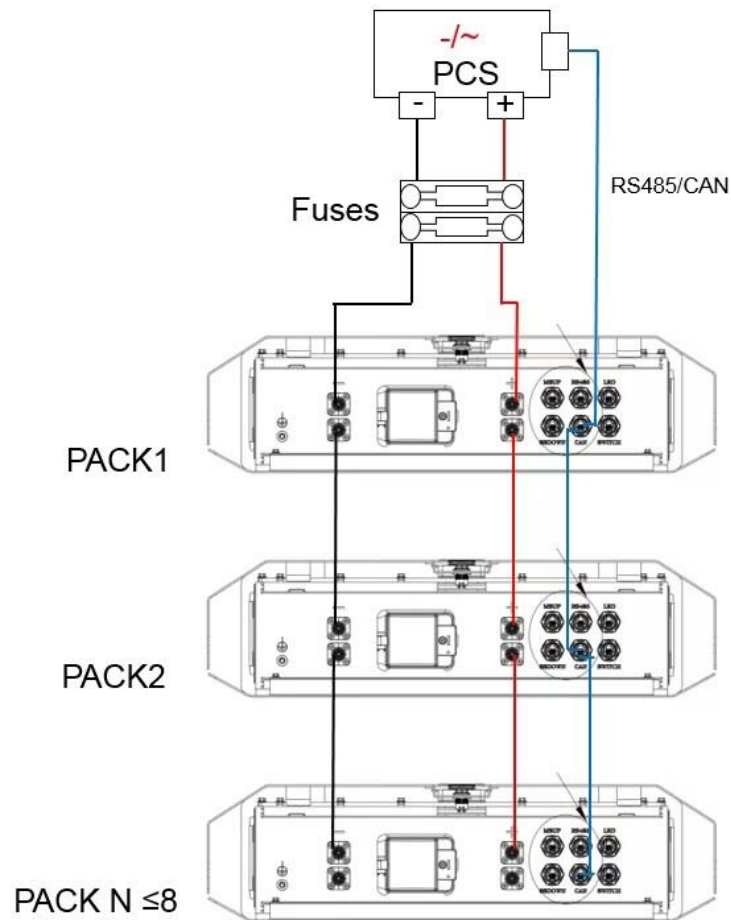

The second wiring method



- By this method, self-prepared terminals and cables for crimping are required. No related accessories are provided in the packing list. Please purchase them by yourself or contact the dealer for purchase.



- The self-crimped parallel cables shall share the same length and please choose the AWG2# cable.
- Please purchase the Combiner box by yourself and its discharge capacity shall be ≥ 1200 A;

In case of parallel battery systems, connect the P+ and P- terminals of each battery system to the P+ and P- terminals of the Combiner box simultaneously and then connect the P± and P- terminals of the Combiner box to PCS, as shown in the figure.

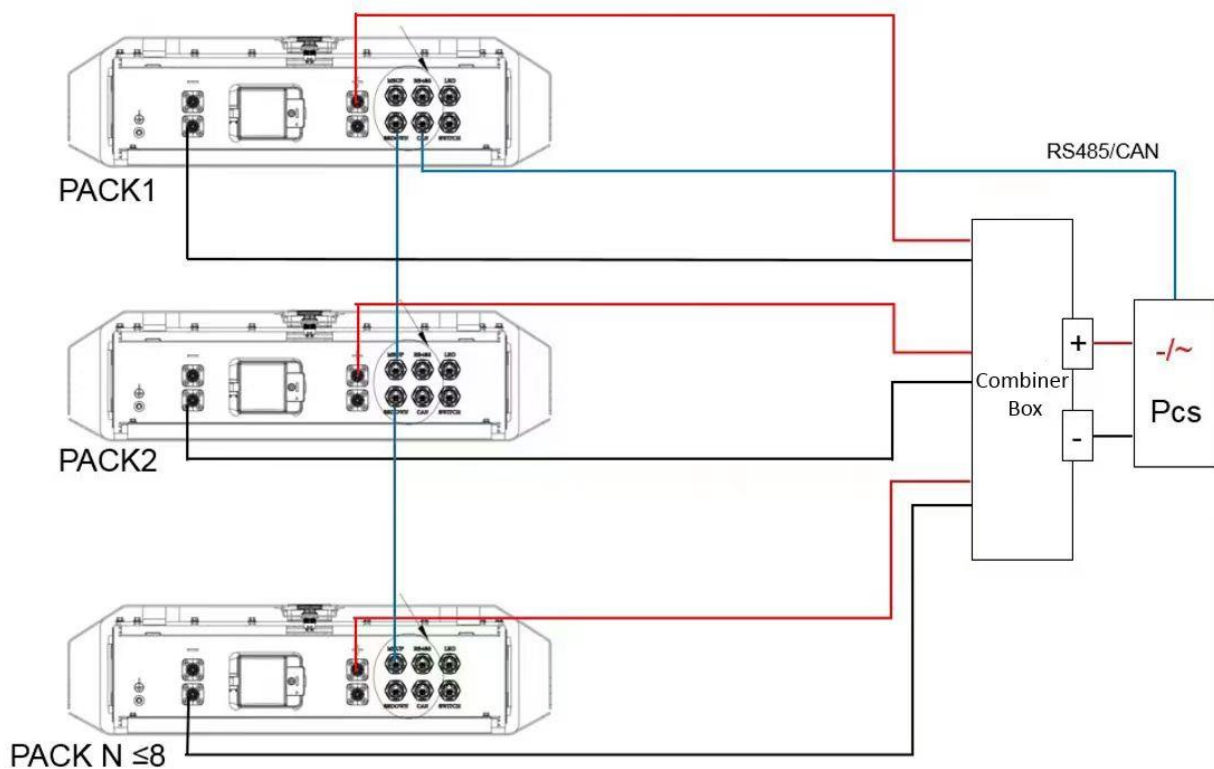

5.2.2 Parallel communication of the battery systems

The main battery system can control and automatically recognize the parallel secondary battery systems through the internal control software. Connection can be made through SSDown and MSUp ports (RJ45 port) to support automatic coding.



- Regarding self crimped communication lines, please use the international standard "T568B" for the wire sequence at both ends.
- After one click power on, press and hold the switch button of the main battery system (Pack1) for 10-14 seconds, and release to automatically assign addresses to the parallel battery systems. After the allocation of addresses is completed, the communication protocol of the inverter can be selected using the upper computer.

The battery systems support at most 8 parallel connections. The energy storage system with 8 batter systems is described as follows.

CAN or RS485 communication port of PACK1 shall be connected to CAN or RS485 of PCS;
 SSDown port of PACK1 shall be connected to MSUp port of PACK2 with communication lines;
 SSDown port of PACK2 shall be connected to MSUp port of PACK3 with communication lines;
 As per the same pattern, the SSDown port of last battery unit (PACK8) shall not be connected.

5.2.3 Grounding



- The ground wire shall be crimped by the installation engineering according to the actual condition. The screw thread connecting bolts shall be M6 and the bolts shall be fully-threaded with a length of 10-14 mm. No requirements are proposed for the type of bolt head.

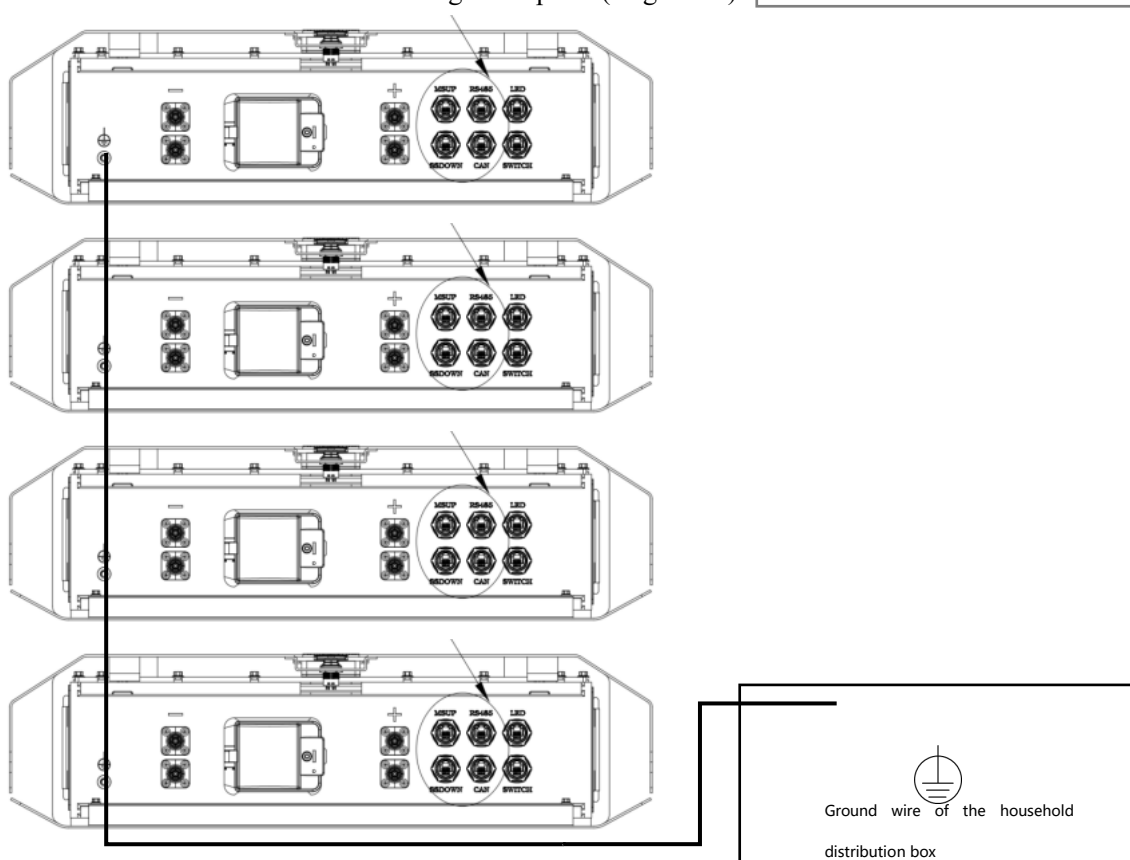
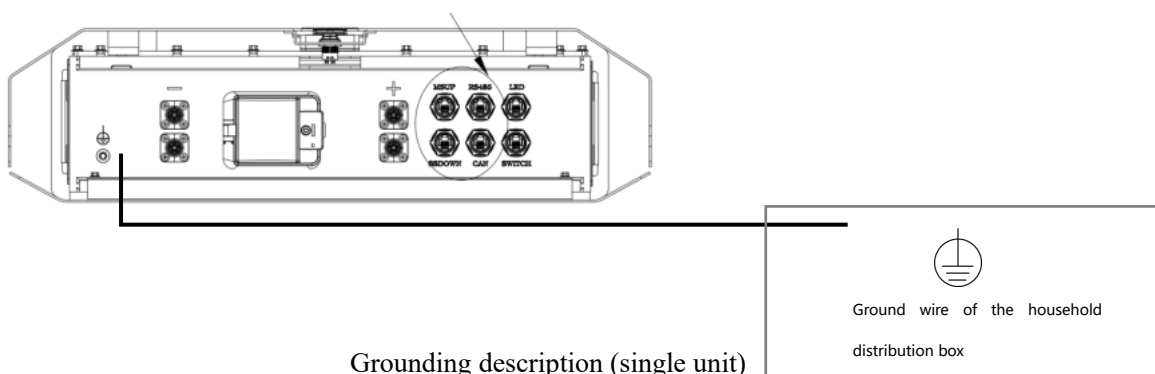

6. Software Commissioning Guideline

6.1 Inverter List and Minimum Number of Battery Systems

Communication & Baud	Protocol Name	Protocol Version	Manufacturer	Model	Minimum number of batteries to be configured
RS485 9600bps	SRNE	V1.3	SRNE	HYP4850S100-H	≥1
	PYLONTECH	V3.6	DEYE	SUN-5K-SG03LP1-EU	≥1
	Growatt	V1.22	Growatt	SPF 5000 ES	≥1
	LUXPOWER	V0.3	LUXPOWER	SNA5000WPV	≥1
	Voltronic	standard	SAKO	SUNPLO-6KW	≥1
	Growatt	V1.22	OTHER	LS-T50248-W60	≥1
	Growatt	V1.22	SACOLAR	M6000HX-48-BP	≥1
CAN 500kbps	Growatt	V1.05	SACOLAR	M6000HX-48-BP	≥1
	Growatt	V1.05	GROWATT	SPF 5000 ES	≥1
	PYLON	V1.3	SOLIS	SS6-EH1P5K-L-PRO	≥1
	LUXPOWER	V1.0	LUXPOWER	SNA5000WPV	≥1
	DEYE	V1.0	DEYE	SUN-5K-SG03LP1-EU	≥1
	SMA	V22	SMA	SI8.0H-12	≥1

6.2 Acquisition of upper computer application program

Please contact your dealer to obtain (online download is not supported).

6.3 Connection between upper computer and battery system

6.3.1 Communication cable production

NOTE

- The communication cable (C1) between the upper computer and the battery system needs to be made by the installation engineer. One end of the communication cable (C1) is DB9-M, and the other end is RJ45, with standard network cables used.

The recommended standard tools for crimping communication lines (C1) are as follows:

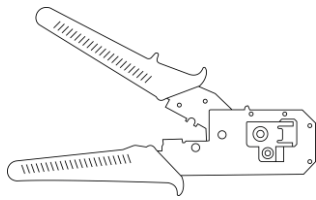

RJ45 crystal head crimping tool

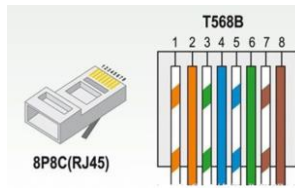

Interface pin number

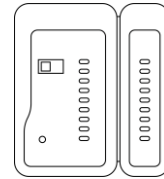

Line sequence tester

Refer to the following figure for the corresponding relationship of wiring (using standard DB9-M as an example):

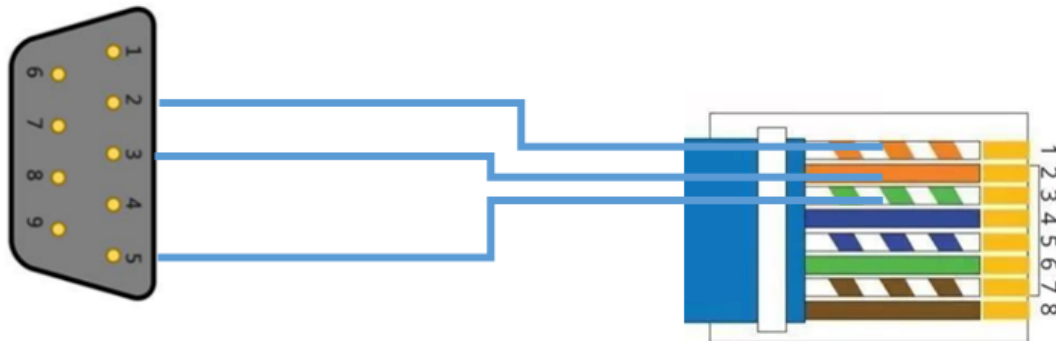

The corresponding pin comparison table is as follows:

USB to RS232 DB9-M		Crystal head 8P8C RJ45	
Pin number	Define	Pin number	Define
2	USBR232_RXD	1	USBR232_RXD
3	USBR232_TXD	2	USBR232_TXD
5	COM_GND	3	COM_GND

6.3.2 Connection of communication interface

C1

NOTICE

- In this system, only the main battery system is allowed to be connected to the PCS. As this product can support different brands of inverters and the communication protocols of inverters from different manufacturers are different, it is necessary to use the upper computer to select the PCS protocol for the main battery system after installation (before use) to ensure that the battery system can be correctly connected to the inverter;
- If the parallel sequence of the battery system changes, please reconfirm the main battery system and reassign the battery system address to ensure that the battery system is correctly connected to the inverter.
- Regardless of whether the battery system is used in parallel or separately, an address needs to be assigned before communicating with the upper computer.

NOTE

- After multiple battery systems are connected in parallel, the battery system that is not connected to the "MSUp" interface is the main battery system, and this battery system is connected to the inverter;
- Any "RS485" or "CAN" interface of the battery system can be connected to the communication line (C1), and can be used for communication between the upper computer software and the battery system.

The sequence of operations is as follows:

- ① Firstly, connect the PCS and battery system as shown in the figure below to form the system;
- ② Press and hold the main battery system switch button for 10-14 seconds to allocate the addresses of all connected battery systems;

- ③ Connect the PC to the main battery system using the USB to RS232 tool  and the completed communication cable (C1)

The connection diagram is as follows:

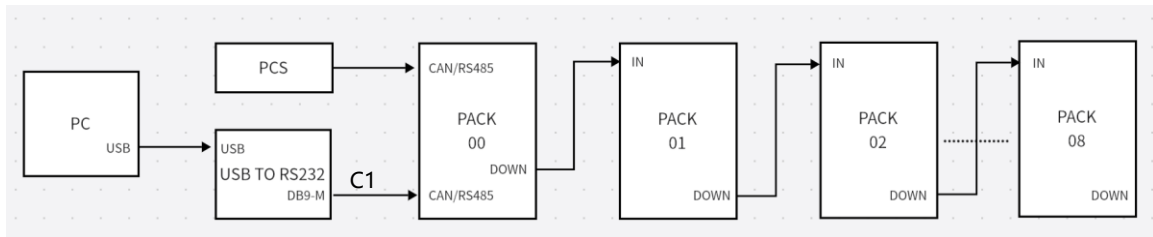

6.3.3 Selection of communication protocol

- ① After the installation of the upper computer is completed, open the upper computer and select the corresponding serial port based on the serial port number of the USB to RS232 tool (the default baud rate is "9600", and the default polling cycle is "1000"). Click on "Connect " and the upper computer will automatically search for single or multiple BMS addresses. Please wait patiently for a few seconds to obtain real-time BMS information.

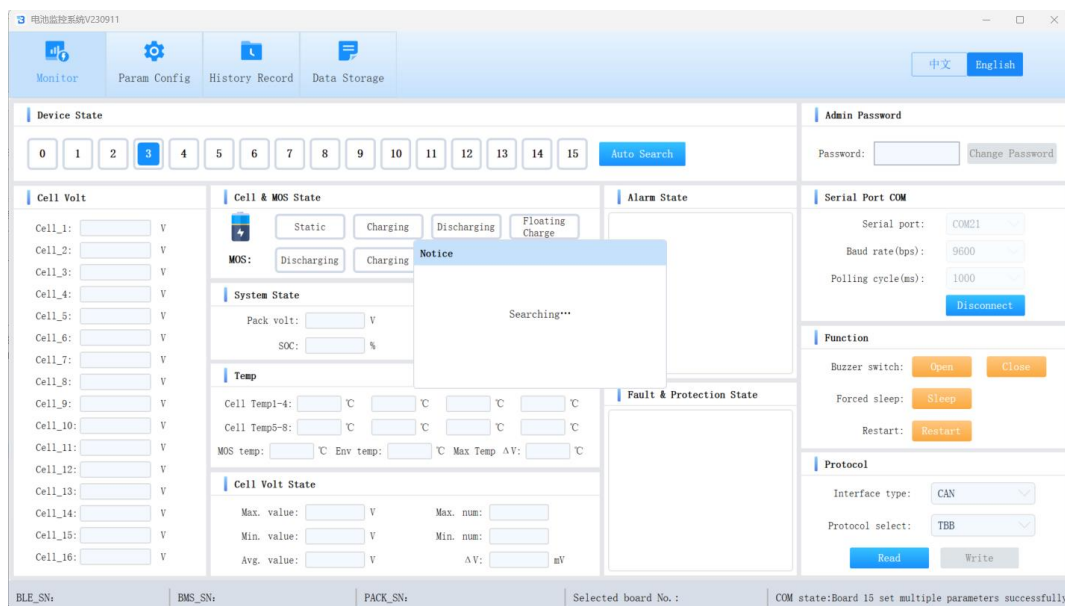
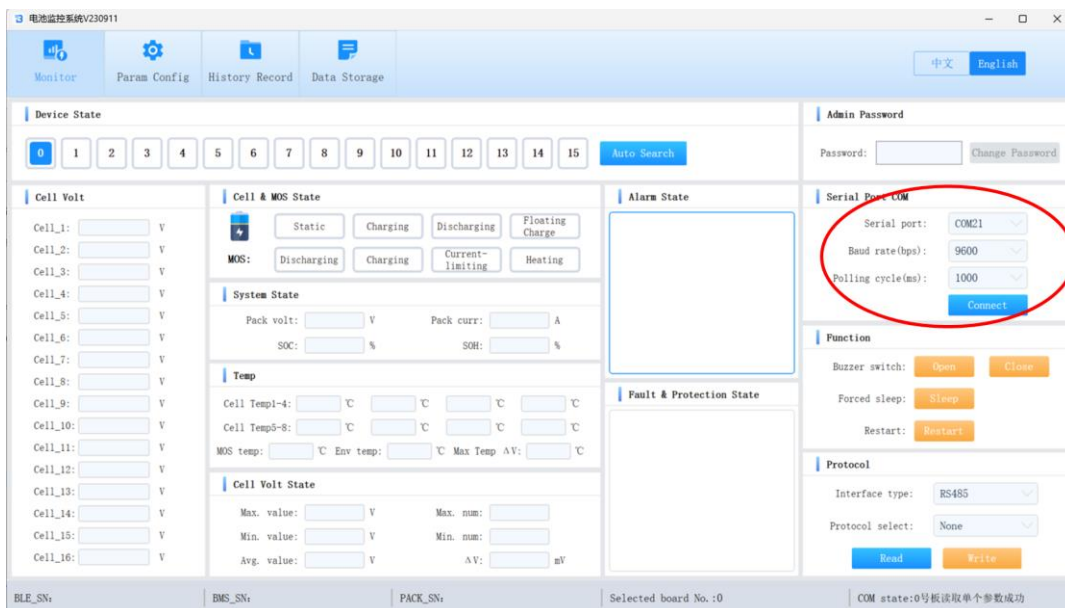

③ When the battery status information is displayed, it indicates that the BMS real-time information has been successfully obtained.

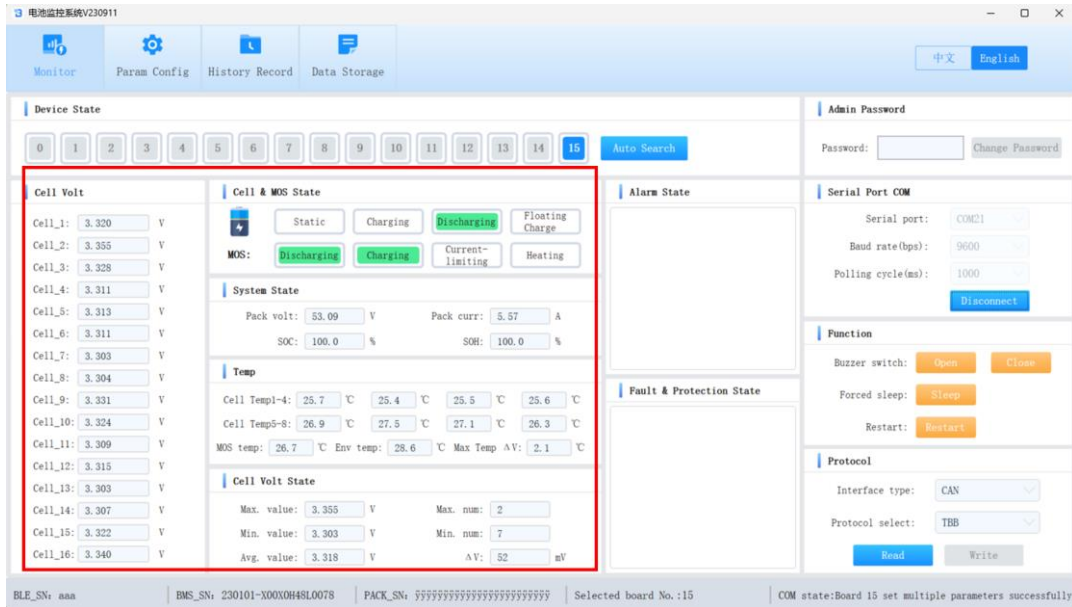

④ In the "Protocol" section, first select "CAN" or "RS485" according to the "Protocol Type (please refer to 6.1)" supported by PCS. Then, click "Protocol Select" to select the protocol supported by the inverter. Finally, click "Write" to set it successfully. Click "Read" to confirm whether the setting was successful again.

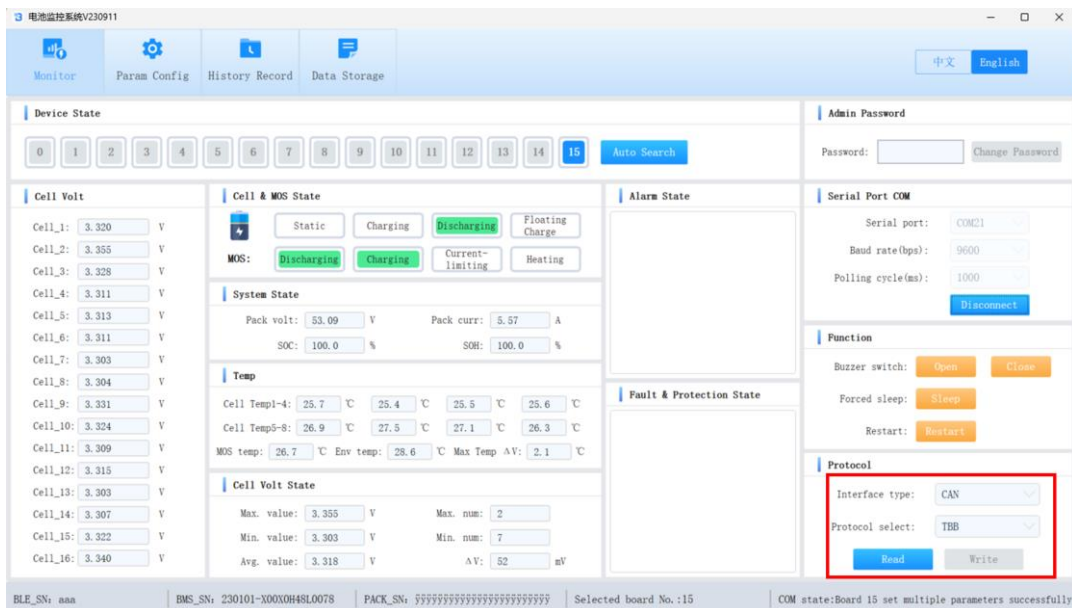

7. Daily Maintenance Guideline

7.1 Safety Precautions



- Wear the insulating gloves when maintaining, operating or dismantling the battery system or its accessories to avoid electric shock.
- Power off the battery system by adjusting the breaker to "OFF" when maintaining, operating or dismantling the battery system or its accessories.
- The internal batteries of the battery system are charged. Non-professionals are prohibited from dismantling or maintaining the battery system.



- Do not dismantle the battery system privately or without authorization. If any fault is indicated by the battery LED light or App, it is suggested to contact the dealer for after-sales services or handle the fault under the guidance of professional technicians.
- When the battery system is powered off by adjusting the breaker to "OFF", the battery casing might still have surplus electricity and heat which may cause electric shock or burning. Therefore, wear the insulating gloves to handle the batteries five minutes after the air switch is turned to "OFF" and the LED indicator light is off.
- Do not expose the batteries to high temperature, outdoor environment, or humidity or install them under the water pipe to prevent battery damage or accidental electric shock.



- Check the battery system for normal operation before installation. In case of battery damage (falling, crashed or swollen batteries, or batteries with pits, etc.), contact the installer or professional operation and maintenance personnel to remove and replace them without delay. Non-professionals shall stay away from the damaged batteries.
- The installation space of the battery system shall be dry and well-ventilated and enjoy great heat dissipation. It is suggested to have the fire-fighting equipment near the battery system.

7.2 Daily Maintenance

To guarantee the normal operation of the battery system for a long term, it is suggested to perform routine maintenance according to the following table in this section. It should be noted that the breaker of the battery system shall be cut off during system cleaning, electrical connection, and grounding reliability maintenance.

Maintenance Content	Inspection/Maintenance Method	Maintenance Cycle	Cautions
Batter system securing	<ul style="list-style-type: none"> • Check the appearance of the battery system for damage or deformation. • Check the fixed bolts of the hanging brackets of the battery system for any loosening. 	Semiannually	Cut off the breaker of the battery system
System cleaning	<ul style="list-style-type: none"> • Check the surface of the battery system box for any dust or dirt. • Check the surface or bottom of the battery system box for any water or leakage. 	Semiannually	Cut off the breaker of the battery system
System	<ul style="list-style-type: none"> • During the normal operation of the battery, check if the 	Semiannually	

operation status	LED indicator light status meets the description in Section 2.5. <ul style="list-style-type: none"> • During the normal operation of the battery, check if the APP parameters are displayed normally. • During the normal operation of the battery, check if there is abnormal sound. 		
Electrical connection	<ul style="list-style-type: none"> • Check the output terminals of the positive and negative poles and communication surface for damage and the fixed bolts for loosening. • Check the cable connection of the energy storage system for shedding and loosening. • Check the cable for damage, especially the cuts or burns on the connecting surface between the cable and metal surface. • Check if the unused DC input terminal, energy storage terminal, COM interface, and water-proof cover are locked. 	Semiannually	Cut off the breaker of the battery system
Grounding reliability	Check of the grounding cable is grounded reliably.	Semiannually	

7.3 Problem Solving

The common problems shall be solved as follows:

NOTE

- The reset operation requires pressing and holding the battery system button for at least 15 seconds

SN	Alarm	Alarm level	Cause	Suggestions
1	Battery over-voltage alarm	Minor	The charging voltage or charging current is too high	<ol style="list-style-type: none"> 1. Discharge or stand the battery until the button light turns into green 2. Contact the dealer if the alarm is not eliminated
2	Battery low voltage alarm	Minor	Battery discharge current too high	<ol style="list-style-type: none"> 1. Charge until the button light turns green. 2. If the alarm is not resolved, please contact the dealer.
3	Battery pressure difference alarm	Minor	Battery system voltage imbalance	<ol style="list-style-type: none"> 1. Allow the battery to stand still or charge at low current for 24 hours. 2. If the alarm is not cleared, please contact the dealer.
4	Charging overcurrent	Minor	Discharge current too high	<ol style="list-style-type: none"> 1. Reduce the charging current.

	alarm			2. If the alarm is not cleared, please contact the dealer.
5	Charging overcurrent protection	Important	Charging current too high	1. Stop charging and it will automatically recover after 60 seconds (if there are more than 3 overcurrent events within 5 minutes, it will be locked, and reset can be attempted to solve the problem).
				2. If the protection is not cleared, please contact the dealer.
6	Discharge overcurrent alarm	Minor	Discharge current too high	1. Reduce the discharge current or stop discharging.
				2. If the alarm is not cleared, please contact the dealer.
7	Discharge overcurrent protection	Important	Discharge current too high	1. Stop discharging and it will automatically recover after 60 seconds (if there are more than 3 overcurrent events within 5 minutes, it will be locked, and resetting can be attempted to solve the problem).
				2. If the protection is not cleared, please contact the dealer.
8	High temperature alarm	Minor	Cell temperature too high	1. Stop battery operation until the alarm disappears.
				2. If the alarm is not cleared, please contact the dealer.
9	Low temperature alarm	Minor	Cell temperature too low	1. Stop using the battery until the alarm disappears.
				2. If the alarm is not cleared, please contact the dealer.
10	Low battery alarm	Important	Battery level below 6%	Charging will automatically resume when the battery level exceeds 10%.
11	Short circuit protection	Important	External short circuit point	1. Check external wiring
				2. If the protection is not eliminated, please contact the dealer.
12	Reverse polarity protection	Important	There may be P+and P - reversed connections in the two battery system	1. Check external wiring
				2. If the protection is not eliminated, please contact the dealer.
13	BMS communication failure	Important	1. Wrong wiring sequence	1. Check the correctness of the wiring.
			2. Inverter protocol selection error	2. Check if the inverter model matches the protocol.
14	Charging/discharging MOS fault	Important	Battery system internal components damaged	1. Charging and discharging are strictly prohibited
				2. Please contact the dealer.

15	Cell failure	Important	Discharge the battery cell below the safe voltage	1. Charging is strictly prohibited
				2. Attemptable reset operation
				3. If the protection is not eliminated, please contact the dealer.
16	Wire breakage protection	Important	Abnormal connection of battery cell voltage sampling line	1. Attemptable reset operation
				2. If the protection is not eliminated, please contact the dealer.。

7.4 Power Requirement for Long-Term Storage

Store the 30% SOC battery at -20°C+45°C/humidity of 5%~95%. In case of long-term storage, battery power shall be maintained to 30%-60% SOC with 0.5C (50A) current.

Charging Conditions During the Storage of 30% SOC Battery			
Ambient temperature	Relative Humidity	Time	SOC
Lower than -20°C	/	Not allowed	/
-20~25°C	5%~95%	≤ 12 months	30%≤SOC≤60%
25~35°C	5%~95%	≤ 6 months	30%≤SOC≤60%
35~45°C	5%~95%	≤ 3 months	30%≤SOC≤60%
Higher than 45°C	/	Not allowed	/

7.5 Emergency Treatment

In case of any of the following or other dangerous accidents, take measures to ensure the personal safety of the onsite personnel and contact the service engineer of our company immediately.

Falling of or strong impact on the battery

- In case of obvious odor, damage, smoke or fire, evacuate people immediately and call the police. Contact the professionals and extinguish the fire with firefighting equipment by the professionals on the premise of safety.
- If no obvious deformation or damage is observed on the battery or there is no obvious odor, damage, smoke or fire, contact the professionals to transfer the battery to an open and safe place or contact the recycling company for disposal.

In case of flooding:

- Power off the system on the premise of personnel safety.
- If any part of the battery is flooded, do not touch the battery to avoid electric shock.
- Do not use the flooded battery and contact the battery recycling company for scrapping.

Smoke or fire

- In case of smoke or fire, if the storage room is full of a large amount of smoke, do open the door or enter the room to avoid fire blast and inhalation of poisonous gas.
- The ignition of lithium battery will release flammable and toxic gases. Therefore, all rescue personnel shall wear full set of fire insulation clothing/fire proximity suit, filtered gas mask or breathing apparatus or fireproof helmet or mask, insulating shoes, etc.

- The fire might last for hours. The extinguished lithium battery may reburn due to the heat release of the residues caused by the damage of the inner cell. After the open fire is extinguished, spray water constantly to cool down the battery until it is $\pm 10^{\circ}\text{C}$ different from the ambient temperature. Monitor the battery for 24 hours and dismount it when there is no sign of heating. Transfer the dismounted battery to a safe place (an open and safe place outside is recommended) and then put it into the fire sandbox or saline water.

Battery leakage

- The leaked electrolytes are colorless, viscous liquids which are flammable and evaporate quickly to leave white salt residue. As a corrosive substance, they feature pungent odor and irritate to the eyes and skin. Do not expose to such electrolytes.
- The professional maintenance and fire personnel shall wear filtered gas mask, personal protective equipment (PPE) and other necessary protective appliance when they deal with the chemical spill incident.

Family members shall not expose to electrolytes and released gases. In case of any exposure, the following measures shall be taken:

- Inhalation: Evacuate the people from the contaminated area to access to fresh air and seek for medical aid immediately.
- Eye contact: wash the eyes with a large amount of clean water for at least 15 minutes and do not rub the eyes. Seek for medical aid immediately.
- Skin contact: wash the contaminated area with a large amount of water and soap and seek for medical aid immediately.
- Intake: Seek for medical aid immediately.

End of emergency and subsequent treatment

- After the battery fire is extinguished, upon checking there is no hidden danger on the site, contact the equipment dealer or installer according to local laws and regulations to handle and recycle the impacted battery by the professionals who wear insulating gloves, insulating shoes, PPE and other equipment. The manufacture may evaluate the damage after the accident and replace the impacted battery according to related procedure to resume the operation of energy storage system.
- After the battery fire is extinguished, the fire-fighting water might pollute the surrounding soil and water source. It is suggested to notify relevant authority to evaluate and deal with the pollution.

8. Contact Information

VREMT Global Service

Company Name: Viridi E-Mobility Technology (Ningbo) Co., Ltd.

Address: No.198 Yinwan East Road, Hangzhou Bay New Zone, Ningbo, Zhejiang Province, P.R. China, 315336

Website: www.vremtglobal.com

Telephone: 4008123486

EUROPE

YES-EU Germany GmbH

Ethan LI

Fengwei.Li1@zeekrlife.com

Telephone: 0031 638226112

Schützenstraße 3A-5, D-65795 Hattersheim am Main, Germany

Shortcut

APP	application
B	
BMS	battery management system
Battery system	a VR-LVB5
D	
DC	direct current
E	
Energy storage system	multiple battery systems are connected in parallel
P	
PCS	Power Conversion System